

REVISIONS

LTR	DESCRIPTION	DATE (YR-MO-DA)	APPROVED
A	Drawing updated to reflect current requirements. - lgt	01-07-06	Raymond Monnin
B	Redrawn. Drawing updated to current requirements. - drw	12-05-01	Charles F. Saffle

THE ORIGINAL FIRST SHEET OF THIS DRAWING HAS BEEN REPLACED.

REV																				
SHEET																				
REV																				
SHEET																				

REV STATUS OF SHEETS	REV	B	B	B	B	B	B	B	B	B	B	B	B	B			
	SHEET	1	2	3	4	5	6	7	8	9	10	11					

PMIC N/A	PREPARED BY Rick C. Officer	<p align="center">DLA LAND AND MARITIME COLUMBUS, OHIO 43218-3990 http://www.landandmaritime.dla.mil</p>													
<p align="center">STANDARD MICROCIRCUIT DRAWING</p> <p>THIS DRAWING IS AVAILABLE FOR USE BY ALL DEPARTMENTS AND AGENCIES OF THE DEPARTMENT OF DEFENSE</p> <p align="center">AMSC N/A</p>	CHECKED BY Charles E. Besore														
	APPROVED BY Michael A. Frye	<p align="center">MICROCIRCUIT, LINEAR, 12-BIT DIGITAL-TO- ANALOG CONVERTER, MONOLITHIC SILICON</p>													
	DRAWING APPROVAL DATE 90-01-23														
	REVISION LEVEL B		SIZE A	CAGE CODE 67268	5962-89617										
		SHEET		1 OF 11											

1. SCOPE

1.1 Scope. This drawing describes device requirements for MIL-STD-883 compliant, non-JAN class level B microcircuits in accordance with MIL-PRF-38535, appendix A.

1.2 Part or Identifying Number (PIN). The complete PIN is as shown in the following example:

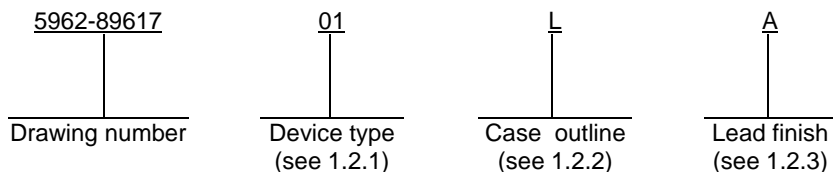

1.2.1 Device type. The device type identifies the circuit function as follows:

<u>Device type</u>	<u>Generic number</u>	<u>Circuit function</u>
01	AD767	12-bit digital-to-analog converter

1.2.2 Case outline. The case outline is as designated in MIL-STD-1835 as follows:

<u>Outline letter</u>	<u>Descriptive designator</u>	<u>Terminals</u>	<u>Package style</u>
L	GDIP3-T24 or CDIP4-T24	24	Dual-in-line

1.2.3 Lead finish. The lead finish is as specified in MIL-PRF-38535, appendix A.

1.3 Absolute maximum ratings.

V_{CC} to power ground	0 V dc to +18 V dc
V_{EE} to power ground.....	0 V dc to -18 V dc
Digital inputs to power ground.....	-1.0 V dc to +7.0 V dc
Reference input to reference ground.....	± 12 V dc
Bipolar offset to reference ground.....	± 12 V dc
10 V span R to reference ground	± 12 V dc
20 V span R to reference ground	± 24 V dc
Ref out or V_{OUT} short circuit duration.....	1/
Storage temperature range	-65°C to +150°C
Lead temperature (soldering, 10 seconds).....	+300°C
Power dissipation	1.0 W
Thermal resistance, junction to case (θ_{JC}).....	See MIL-STD-1835
Thermal resistance, junction to ambient (θ_{JA})	80°C/W
Junction temperature (T_J).....	+175°C

1.4 Recommended operating conditions.

Positive supply voltage range (V_{CC})	+12 V dc to +15 V dc
Negative supply voltage range (V_{EE})	-12 V dc to -15 V dc
Ambient operating temperature range (T_A)	-55°C to +125°C

1/ Indefinite short to power ground; momentary short to V_{CC} .

STANDARD MICROCIRCUIT DRAWING DLA LAND AND MARITIME COLUMBUS, OHIO 43218-3990	SIZE A		5962-89617
		REVISION LEVEL B	SHEET 2

2. APPLICABLE DOCUMENTS

2.1 Government specification, standards, and handbooks. The following specification, standards, and handbooks form a part of this drawing to the extent specified herein. Unless otherwise specified, the issues of these documents are those cited in the solicitation or contract.

DEPARTMENT OF DEFENSE SPECIFICATION

MIL-PRF-38535 - Integrated Circuits, Manufacturing, General Specification for.

DEPARTMENT OF DEFENSE STANDARDS

MIL-STD-883 - Test Method Standard Microcircuits.
MIL-STD-1835 - Interface Standard Electronic Component Case Outlines.

DEPARTMENT OF DEFENSE HANDBOOKS

MIL-HDBK-103 - List of Standard Microcircuit Drawings.
MIL-HDBK-780 - Standard Microcircuit Drawings.

(Copies of these documents are available online at <https://assist.daps.dla.mil/quicksearch/> or from the Standardization Document Order Desk, 700 Robbins Avenue, Building 4D, Philadelphia, PA 19111-5094.)

2.2 Order of precedence. In the event of a conflict between the text of this drawing and the references cited herein, the text of this drawing takes precedence. Nothing in this document, however, supersedes applicable laws and regulations unless a specific exemption has been obtained.

3. REQUIREMENTS

3.1 Item requirements. The individual item requirements shall be in accordance with MIL-PRF-38535, appendix A for non-JAN class level B devices and as specified herein. Product built to this drawing that is produced by a Qualified Manufacturer Listing (QML) certified and qualified manufacturer or a manufacturer who has been granted transitional certification to MIL-PRF-38535 may be processed as QML product in accordance with the manufacturers approved program plan and qualifying activity approval in accordance with MIL-PRF-38535. This QML flow as documented in the Quality Management (QM) plan may make modifications to the requirements herein. These modifications shall not affect form, fit, or function of the device. These modifications shall not affect the PIN as described herein. A "Q" or "QML" certification mark in accordance with MIL-PRF-38535 is required to identify when the QML flow option is used.

3.2 Design, construction, and physical dimensions. The design, construction, and physical dimensions shall be as specified in MIL-PRF-38535, appendix A and herein.

3.2.1 Case outline. The case outline shall be in accordance with 1.2.2 herein.

3.2.2 Terminal connections. The terminal connections shall be as specified on figure 1.

3.2.3 Functional block diagram. The Functional block diagram shall be as specified on figure 2.

3.3 Electrical performance characteristics. Unless otherwise specified herein, the electrical performance characteristics are as specified in table I and shall apply over the full ambient operating temperature range.

3.4 Electrical test requirements. The electrical test requirements shall be the subgroups specified in table II. The electrical tests for each subgroup are described in table I.

STANDARD MICROCIRCUIT DRAWING DLA LAND AND MARITIME COLUMBUS, OHIO 43218-3990	SIZE A		5962-89617
		REVISION LEVEL B	SHEET 3

TABLE I. Electrical performance characteristics.

Test	Symbol	Conditions -55°C ≤ T _A ≤ +125°C ^{1/} unless otherwise specified	Group A subgroups	Device type	Limits		Unit
					Min	Max	
Relative accuracy	RA	All bits with positive errors on and all bits with negative errors on	1, 2, 3	01		±1.0	LSB
Differential nonlinearity	DNL	Major carry errors	1, 2, 3	01		±1.0	LSB
Gain error ^{2/}	A _E	All bits on, T _A = +25°C	1	01		±0.2	%FSR
Gain temperature coefficient	$\frac{\Delta A_E}{\Delta T}$	All bits on	2, 3	01		±30	ppm/°C
Unipolar offset error	V _{OS}	All bits off, T _A = +25°C	1	01		±2.0	LSB
Unipolar offset temperature coefficient	$\frac{\Delta V_{OS}}{\Delta T}$	All bits off	2, 3	01		±3.0	ppm/°C
Bipolar zero error ^{2/}	B _{PZE}	MSB on, all other bits off, bipolar mode, T _A = +25°C	1	01		±0.1	%FSR
Bipolar zero temperature coefficient	$\frac{\Delta B_{PZE}}{\Delta T}$	MSB on, all other bits off, bipolar mode	2, 3	01		±10	ppm/°C
Reference input ^{3/} resistance	R _{IN}	T _A = +25°C	4	01	15	25	kΩ
Reference output voltage	V _{REF}	Unipolar mode, 1.1 mA external load	1, 2, 3	01	9.9	10.1	V
Output current ^{3/}	I _{OUT}		1, 2, 3	01	±5.0		mA
Output short circuit ^{3/} current	I _{SC}		1, 2, 3	01		40	mA
Power supply rejection ratio	PSRR	+11.4 V ≤ V _{CC} ≤ +16.5 V	1	01		±10	ppm of FSR/%
			2, 3			±20	
		-11.4 V ≤ V _{EE} ≤ -16.5 V	1			±10	
			2, 3			±20	
Power supply current	I _{CC}	V _{CC} = +16.5 V, T _A = +25°C, all bits on	1, 2, 3	01		+13	mA
	I _{EE}	V _{EE} = -16.5 V, T _A = +25°C, all bits off				-23	

See footnotes at end of table.

**STANDARD
MICROCIRCUIT DRAWING**
DLA LAND AND MARITIME
COLUMBUS, OHIO 43218-3990

SIZE
A

5962-89617

REVISION LEVEL
B

SHEET
4

TABLE I. Electrical performance characteristics - continued.

Test	Symbol	Conditions -55°C ≤ T _A ≤ +125°C 1/ unless otherwise specified		Group A subgroups	Device type	Limits		Unit
						Min	Max	
Digital input high voltage	V _{IH}			1, 2, 3	01	2.0		V
Digital input low voltage	V _{IL}			1	01		0.8	V
				2, 3			0.7	
Digital input high current	I _{IH}	V _{IH} = 5.5 V, T _A = +25°C		1	01		10	μA
Digital input low current	I _{IL}	V _{IL} = 0.0 V, T _A = +25°C		1	01		5	μA
Data setup time	t _{DS}	See figure 3 4/		9, 10, 11	01	90		ns
Data hold time	t _{DH}			9, 10, 11	01	20		ns
$\overline{\text{CS}}$ pulse width	t _{CP}			9, 10, 11	01	90		ns
Output voltage settling time	t _{SL}	R _L = 2.0 kΩ, C _L = 500 pF, See figure 3 4/	R _{FB} = 10 kΩ	9, 10, 11	01		4.0	μs
			R _{FB} = 5 kΩ				3.0	

1/ V_{CC} = +15 V, V_{EE} = -15 V, 50Ω resistor between pin 6 and pin 7, $\overline{\text{CS}}$ = logic 0, V_{IH} = 2.0 V, V_{IL} = 0.8 V and unipolar 10 V configuration, unless otherwise specified.

2/ Adjustable to 0 V.

3/ If not tested, shall be guaranteed to the limits specified in table I.

4/ V_{CC} = +12 V or +15 V and V_{EE} = -12 V or -15 V.

**STANDARD
MICROCIRCUIT DRAWING**
DLA LAND AND MARITIME
COLUMBUS, OHIO 43218-3990

SIZE
A

5962-89617

REVISION LEVEL
B

SHEET
5

Device type	01
Case outline	L
Terminal Number	Terminal symbol
1	20 V SPAN
2	10 V SPAN
3	SUM JCT
4	BIP OFF
5	AGND
6	REF OUT
7	REF IN
8	V _{CC}
9	V _{OUT}
10	V _{EE}
11	$\overline{\text{CS}}$
12	DGND
13	DB ₀ (LSB)
14	DB ₁
15	DB ₂
16	DB ₃
17	DB ₄
18	DB ₅
19	DB ₆
20	DB ₇
21	DB ₈
22	DB ₉
23	DB ₁₀
24	DB ₁₁ (MSB)

FIGURE 1. Terminal connections.

STANDARD MICROCIRCUIT DRAWING DLA LAND AND MARITIME COLUMBUS, OHIO 43218-3990	SIZE A		5962-89617
		REVISION LEVEL B	SHEET 6

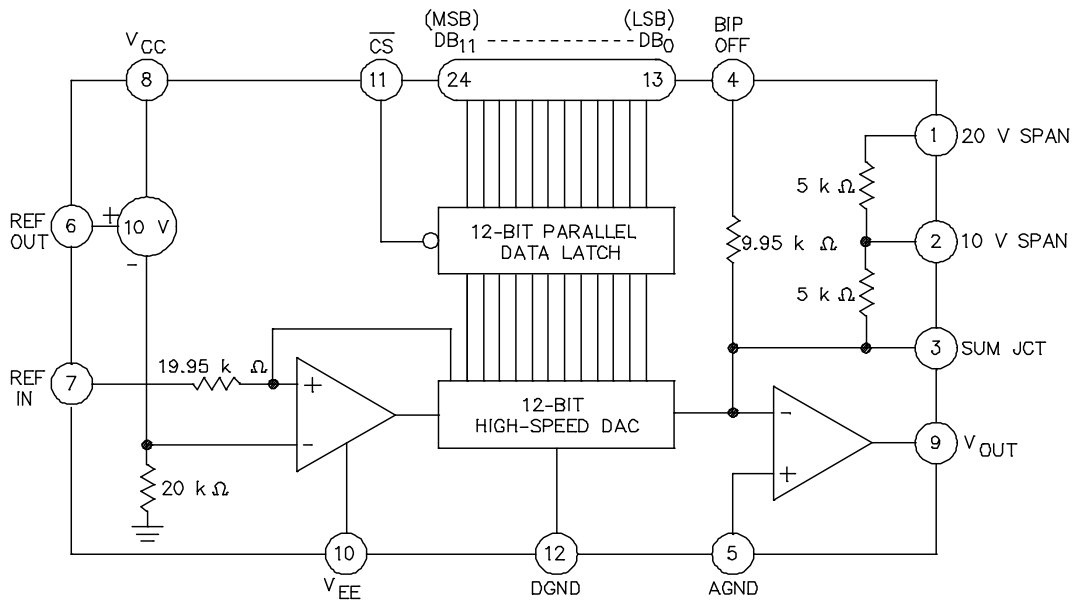

Output range	Digital input codes	Connect pin 9 to	Connect pin 1 to	Connect pin 2 to	Connect pin 4 to
±10 V	Offset binary	1	9	NC	6 (through 50 Ω fixed or 100Ω trim resistor)
±5 V	Offset binary	1 and 2	2 and 9	1 and 9	6 (through 50 Ω fixed or 100Ω trim resistor)
±2.5 V	Offset binary	2	3	9	6 (through 50 Ω fixed or 100Ω trim resistor)
0 to +10 V	Straight binary	1 and 2	2 and 9	1 and 9	5 (or optional trim – see figure 2)
0 to +5 V	Straight binary	2	3	9	5 (or optional trim – see figure 2)

Output voltage range connections

FIGURE 2. Functional block diagram.

**STANDARD
MICROCIRCUIT DRAWING**
DLA LAND AND MARITIME
COLUMBUS, OHIO 43218-3990

SIZE
A

5962-89617

REVISION LEVEL
B

SHEET
7

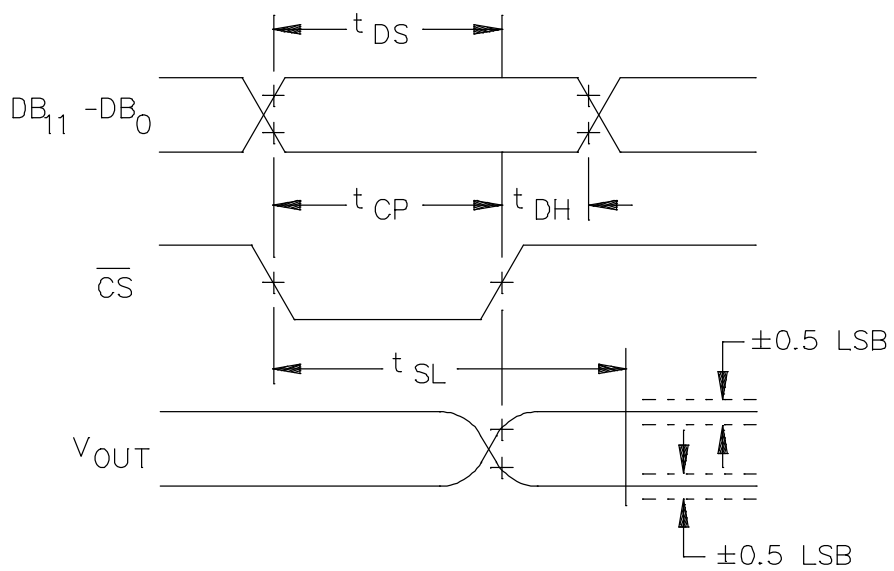

FIGURE 3. Timing diagram.

**STANDARD
MICROCIRCUIT DRAWING**
DLA LAND AND MARITIME
COLUMBUS, OHIO 43218-3990

SIZE
A

5962-89617

REVISION LEVEL
B

SHEET
8

3.5 Marking. Marking shall be in accordance with MIL-PRF-38535, appendix A. The part shall be marked with the PIN listed in 1.2 herein. In addition, the manufacturer's PIN may also be marked. For packages where marking of the entire SMD PIN number is not feasible due to space limitations, the manufacturer has the option of not marking the "5962-" on the device.

3.5.1 Certification/compliance mark. A compliance indicator "C" shall be marked on all non-JAN devices built in compliance to MIL-PRF-38535, appendix A. The compliance indicator "C" shall be replaced with a "Q" or "QML" certification mark in accordance with MIL-PRF-38535 to identify when the QML flow option is used.

3.6 Certificate of compliance. A certificate of compliance shall be required from a manufacturer in order to be listed as an approved source of supply in MIL-HDBK-103 (see 6.6 herein). The certificate of compliance submitted to DLA Land and Maritime -VA prior to listing as an approved source of supply shall affirm that the manufacturer's product meets the requirements of MIL-PRF-38535, appendix A and the requirements herein.

3.7 Certificate of conformance. A certificate of conformance as required in MIL-PRF-38535, appendix A shall be provided with each lot of microcircuits delivered to this drawing.

3.8 Notification of change. Notification of change to DLA Land and Maritime -VA shall be required for any change that affects this drawing.

3.9 Verification and review. DLA Land and Maritime, DLA Land and Maritime's agent, and the acquiring activity retain the option to review the manufacturer's facility and applicable required documentation. Offshore documentation shall be made available onshore at the option of the reviewer.

4. VERIFICATION

4.1 Sampling and inspection. Sampling and inspection procedures shall be in accordance with MIL-PRF-38535, appendix A.

4.2 Screening. Screening shall be in accordance with method 5004 of MIL-STD-883, and shall be conducted on all devices prior to quality conformance inspection. The following additional criteria shall apply:

a. Burn-in test, method 1015 of MIL-STD-883.

(1) Test condition A, B, C or D. The test circuit shall be maintained by the manufacturer under document revision level control and shall be made available to the preparing or acquiring activity upon request. The test circuit shall specify the inputs, outputs, biases, and power dissipation, as applicable, in accordance with the intent specified in method 1015 of MIL-STD-883.

(2) T_A = +125°C, minimum.

b. Interim and final electrical test parameters shall be as specified in table II herein, except interim electrical parameter tests prior to burn-in are optional at the discretion of the manufacturer.

STANDARD MICROCIRCUIT DRAWING DLA LAND AND MARITIME COLUMBUS, OHIO 43218-3990	SIZE A		5962-89617
		REVISION LEVEL B	SHEET 9

TABLE II. Electrical test requirements.

MIL-STD-883 test requirements	Subgroups (in accordance with MIL-STD-883, method 5005, table I)
Interim electrical parameters (method 5004)	1
Final electrical test parameters (method 5004)	1*, 2, 3
Group A test requirements (method 5005)	1, 2, 3, 4**, 9**, 10**, 11**
Groups C and D end-point electrical parameters (method 5005)	1

* PDA applies to subgroup 1.

** Subgroups 4, 9, 10, and 11, if not tested shall be guaranteed to the limits specified in table I herein.

4.3 Quality conformance inspection. Quality conformance inspection shall be in accordance with method 5005 of MIL-STD-883 including groups A, B, C, and D inspections. The following additional criteria shall apply.

4.3.1 Group A inspection.

- a. Tests shall be as specified in table II herein.
- b. Subgroups 5, 6, 7, and 8 in table I, method 5005 of MIL-STD-883 shall be omitted.

4.3.2 Groups C and D inspections.

- a. End-point electrical parameters shall be as specified in table II herein.
- b. Steady-state life test conditions, method 1005 of MIL-STD-883.
 - (1) Test condition A, B, C or D. The test circuit shall be maintained by the manufacturer under document revision level control and shall be made available to the preparing or acquiring activity upon request. The test circuit shall specify the inputs, outputs, biases, and power dissipation, as applicable, in accordance with the intent specified in method 1005 of MIL-STD-883.
 - (2) $T_A = +125^{\circ}\text{C}$, minimum.
 - (3) Test duration: 1,000 hours, except as permitted by method 1005 of MIL-STD-883.

STANDARD MICROCIRCUIT DRAWING DLA LAND AND MARITIME COLUMBUS, OHIO 43218-3990	SIZE A		5962-89617
		REVISION LEVEL B	SHEET 10

5. PACKAGING

5.1 Packaging requirements. The requirements for packaging shall be in accordance with MIL-PRF-38535, appendix A.

6. NOTES

6.1 Intended use. Microcircuits conforming to this drawing are intended for use for Government microcircuit applications (original equipment), design applications, and logistics purposes.

6.2 Replaceability. Microcircuits covered by this drawing will replace the same generic device covered by a contractor-prepared specification or drawing.

6.3 Configuration control of SMD's. All proposed changes to existing SMD's will be coordinated with the users of record for the individual documents. This coordination will be accomplished using DD Form 1692, Engineering Change Proposal.

6.4 Record of users. Military and industrial users shall inform DLA Land and Maritime when a system application requires configuration control and the applicable SMD to that system. DLA Land and Maritime will maintain a record of users and this list will be used for coordination and distribution of changes to the drawings. Users of drawings covering microelectronics devices (FSC 5962) should contact DLA Land and Maritime -VA, telephone (614) 692-0544.

6.5 Comments. Comments on this drawing should be directed to DLA Land and Maritime -VA, Columbus, Ohio 43218-3990, or telephone (614) 692-0540.

6.6 Approved sources of supply. Approved sources of supply are listed in MIL-HDBK-103. The vendors listed in MIL-HDBK-103 have agreed to this drawing and a certificate of compliance (see 3.6 herein) has been submitted to and accepted by DLA Land and Maritime -VA.

STANDARD MICROCIRCUIT DRAWING DLA LAND AND MARITIME COLUMBUS, OHIO 43218-3990	SIZE A		5962-89617
		REVISION LEVEL B	SHEET 11

STANDARD MICROCIRCUIT DRAWING BULLETIN

DATE: 12-05-01

Approved sources of supply for SMD 5962-89617 are listed below for immediate acquisition information only and shall be added to MIL-HDBK-103 and QML-38535 during the next revision. MIL-HDBK-103 and QML-38535 will be revised to include the addition or deletion of sources. The vendors listed below have agreed to this drawing and a certificate of compliance has been submitted to and accepted by DLA Land and Maritime -VA. This information bulletin is superseded by the next dated revision of MIL-HDBK-103 and QML-38535. DLA Land and Maritime maintains an online database of all current sources of supply at <http://www.landandmaritime.dla.mil/Programs/Smcr/>.

Standard microcircuit drawing PIN <u>1/</u>	Vendor CAGE number	Vendor similar PIN <u>2/</u>
5962-8961701LA	24355	AD767SD/883B

1/ The lead finish shown for each PIN representing a hermetic package is the most readily available from the manufacturer listed for that part. If the desired lead finish is not listed contact the vendor to determine its availability.

2/ Caution. Do not use this number for item acquisition. Items acquired to this number may not satisfy the performance requirements of this drawing.

Vendor CAGE
number

24355

Vendor name
and address

Analog Devices, Inc.
Rt. 1 Industrial Park
P.O. Box 9106
Norwood, Ma. 02062
Point of Contact: 804 Woburn Street
Wilmington, MA 01887-3462

The information contained herein is disseminated for convenience only and the Government assumes no liability whatsoever for any inaccuracies in the information bulletin.